

# DYNAPAC

Part of the Atlas Copco Group

## CC800

### Double drum vibratory rollers



#### Technical data

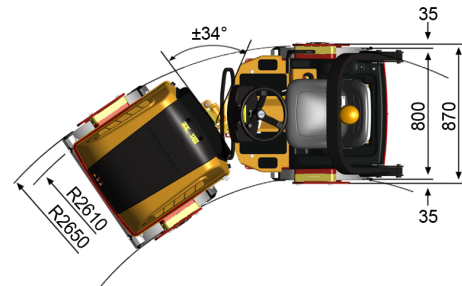
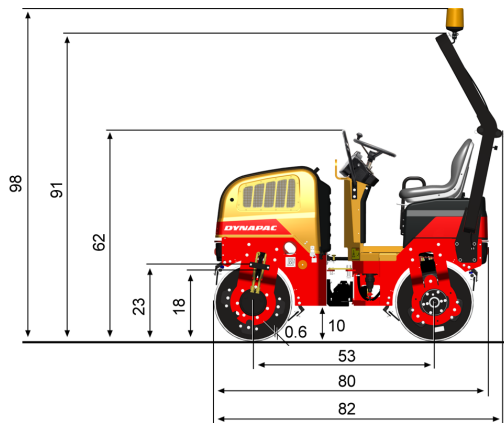

<b>Masses</b>	<b>CC800</b>
Max. operating mass	3,700 lbs
Operating mass (incl. ROPS)	3,500 lbs
Module mass (front/ rear)	1,600/ 1,800 lbs
<b>Propulsion</b>	
Speed range	0-6
Vertical oscillation	±13°
Theor. gradeability	40 %
<b>Compaction</b>	
Centrifugal force	3,800 lb
Nominal amplitude	0.016 in
Static linear load (front/ rear)	52/ 56 lbs/ in
Vibration frequency	4,200 vpm
Water tank (gal)	50 gal.
Water tank	50 gal
<b>Engine</b>	
Manufacturer/ Model	Perkins 403D-11
Type	Water cooled diesel
Rated power, SAE J1995	23.5 hp @ 2,600 rpm
Fuel tank capacity	6 gal
<b>Hydraulic system</b>	
Driving	Axial piston pump with variable displacement and servo. 2 radial piston motors with constant displacement.
Vibration	Gear pump/ motors with constant displacement.
Steering	Gear pump with constant displacement.
Service brake	Hydrostatic in forward and reverse lever.
Parking/ Emergency brake	Failsafe brake in both drums.
<b>Standard equipment</b>	

#### Dynapac USA

3700 East 68th Avenue, Commerce City, CO 80022 Phone: 800-732-6762 Fax: 303-288-8828

Find your local dealer at [www.dynapac.us](http://www.dynapac.us)

We reserve the right to change specifications without notice. Photos and illustrations do not always show standard versions of machines.  
The above information is a general description only, all informations are supplied without liability.

Standard equipment

Automatic Vibration Control (AVC), Automatic Water Control (AWC),  
Back up alarm, Central lifting eye, Cup/ Can holder, Emergency stop, Foldable ROPS,  
Fuel gauge, Horn, Hourmeter, Hydraulic pressure checkpoints, Ignition key,  
Interlock brake, Pressurized sprinkler system, Rubber mounted operator's platform,  
Seat belt, Sprinkler timer, Towing eyelet front/ rear, Vibrations on both drums,  
Warning lights; Brake - Charging - Engine oil pressure - Engine water temperature - Low fuel level

**Dynapac USA**

3700 East 68th Avenue, Commerce City, CO 80022 Phone: 800-732-6762 Fax: 303-288-8828

Find your local dealer at [www.dynapac.us](http://www.dynapac.us)

We reserve the right to change specifications without notice. Photos and illustrations do not always show standard versions of machines.  
The above information is a general description only, all informations are supplied without liability.